



# Winding Ohmmeter & Tap Changer Analyzer RMO40T

- Lightweight – 9,5 kg
- Test current 5 mA – 40 A DC
- Measuring range 0,1  $\mu\Omega$  - 2 k $\Omega$
- Two voltage sense channels
- Extremely quick measurement
- Automatic discharge circuit



## High DC current resistance meter for transformers & tap changer analyzer

### Description

The Winding Ohmmeter & Tap Changer Analyzer RMO40T is designed for resistance measurement of inductive test objects. RMO40T generates true DC ripple free current. Both injection of current and discharge of energy from the inductance are automatically regulated. RMO40T injects current with a voltage as high as 60 V. This ensures that the duration of test is as short as possible, and that the desired test current is reached faster. Two independent channels enable testing of two series windings, or primary and secondary windings. There is enough memory within RMO40T instrument to store 500 measurements. All measurements are time and date stamped.

The set is equipped with thermal and overcurrent protection. The RMO40T has very high ability to cancel electrostatic and electromagnetic interference in HV electric fields. It is achieved by very efficient filtration. The filtration is made utilizing appropriate hardware and software.

### On Load Tap Changers

The RMO40T can be used to measure winding resistance of individual taps of a power transformer's tap changer. It can also check whether the on-load tap changer (OLTC) switches without an interruption. The moment a tap position is changed from one tap to another, the device detects a sudden, very short drop of the current. A properly working tap changer differs from a malfunctioning one. This is obvious from an interruption during the change, by the magnitude of the current ripple and also by the transition time. Malfunctioning behaviour of Tap Changer will result in much higher current ripple value and by changed transition time than a properly functioning Tap Changer. The Tap Changer Control Unit allows the operator to control the Tap Changer operation box from the RMO40T position.

### DV-Win

Using DV-Win software, tests could be performed from a PC, and results can be obtained directly at a PC. The DV-Win software allows results to be arranged in an Excel spreadsheet, which can be shown later as a diagram and printed for a report, or ASCII format. This software can control the RMO-T instrument, allowing a condition assessment of OLTC (tap changer) analyzing the graph which represents dynamic resistance during the tap change. Using DV-Win and RMO40T it is possible to perform heat run test on distribution and power transformers.



## Typical application

Typical application of RMO40T is measuring the resistance of:

- ✓ Power transformers
- ✓ On-Load Tap Changers
- ✓ Generators and electrical motors
- ✓ High-current busbar joints
- ✓ Cable splices



## Standard accessories

- ✓ DV-Win PC software
- ✓ Current cables 2 x 10 m 10 mm<sup>2</sup>
- ✓ Sense cables 2 x 2 x 10 m 2,5 mm<sup>2</sup>
- ✓ Current connection cable 1 x 5 m 10 mm<sup>2</sup>
- ✓ Mains power cable
- ✓ Ground (PE) cable
- ✓ Cable bag

		
Voltage sense cables	Current cables	Current connection cable

## Optional accessories

- ✓ Built-in thermal printer
- ✓ Test shunt 75 A / 150 mV
- ✓ Built-in Tap Changer Control Unit
- ✓ Tap Changer Control cable set 5 m
- ✓ Current cables 2 x 15 m 10 mm<sup>2</sup>
- ✓ Sense cables 2 x 2 x 15 m 2,5 mm<sup>2</sup>
- ✓ Cable plastic case

		
RMO40T	Shunt	Cable bag

## Connecting a Test Object to RMO40T

The RMO40T should be turned off, connection between RMO40T and the test object is such that the measuring cables from the "Voltage Sense" sockets are attached as close as possible to the measured resistance, while they are connected between the current feeding cables. That way, resistance of cables and clamps is almost completely excluded from the resistance measured. The figure to the right shows simultaneous testing of both windings (high and low) on a single-phase transformer. In such a way, it is possible to speed up the measurement when two channels are used to test both windings of the transformer.

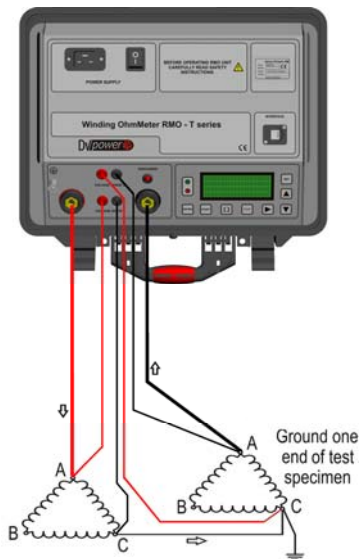
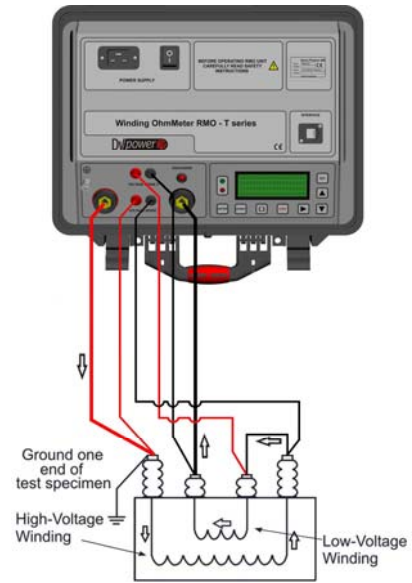

Testing of a Delta-delta winding resistance is usually a very time consuming procedure. This is because the two windings represent two closed loop inductors. When energy is brought into the inductors, this energy (in the form of D.C. current) continually circulates within each winding. To test this configuration quickly, both high and low sides should be connected in series with the current source of a Transformer Ohmmeter. By having these two windings in opposing polarity, the internal circulating currents settle very quickly to obtain a balance, and discharge with the same speed. Even if only one side of the transformer needs to be tested, connecting both high and low

Using RMO40T's Tap Changer menu, the power transformer winding resistance of individual tap positions can be measured. Also, you can check whether the on-load tap changer switches without an interruption. The RMO40T current output injects a constant current into a power transformer. This current and voltage value is measured, and the winding resistance is calculated.

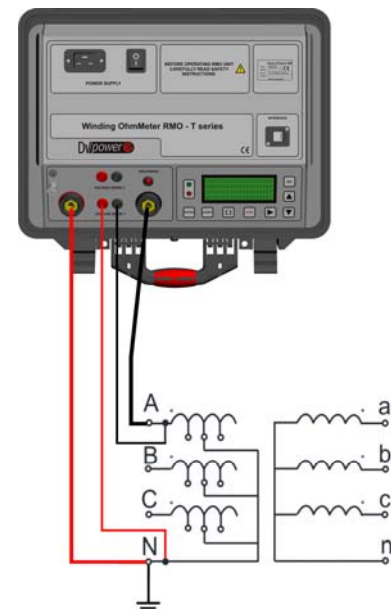

## Technical data

### 1 - Mains Power Supply

- Connection according to IEC/EN60320-1; UL498, CSA 22.2
- Voltage single phase 110 V – 240 V AC, + 10 % - -15 %
- Frequency 50 / 60 Hz

### 2 - Output data

- Test current 5 mA DC – 40 A DC
- Measuring range / Resolution
  - 0,1  $\mu\Omega$  - 999,9  $\mu\Omega$  0,1  $\mu\Omega$
  - 1,000 m $\Omega$  - 9,999 m $\Omega$  1  $\mu\Omega$
  - 10,00 m $\Omega$  - 99,99 m $\Omega$  10  $\mu\Omega$
  - 100,0 m $\Omega$  - 999,9 m $\Omega$  0,1 m $\Omega$
  - 1,000  $\Omega$  - 99,99  $\Omega$  10 m $\Omega$
  - 100,0  $\Omega$  - 999,9  $\Omega$  0,1  $\Omega$
  - 1000  $\Omega$  - 2000  $\Omega$  1  $\Omega$
- Typical accuracy  $\pm(0,2 \% \text{ rdg} + 0,2 \% \text{ FS})$

### 3 – Environmental conditions

- Operating temperature  $-10^{\circ}\text{C} - +50^{\circ}\text{C} / 14^{\circ}\text{F} - +122^{\circ}\text{F}$
- Storage and transportation  $-25^{\circ}\text{C} - +70^{\circ}\text{C} / -13^{\circ}\text{F} - +158^{\circ}\text{F}$
- Humidity 5 % - 95 % relative humidity, non condensing

### 4 - Dimensions and Weight

- Dimensions 410 mm x 180 mm x 320 mm  
16,14 in x 7,08 in x 12,59 in  
(W x H x D) without handle
- Weight 9,5 kg / 20,9 lb

### 5– Safety Standards

- European standards EN 61010-1  
LVD 73/23/EEC
- International standards IEC 61010-1  
UL 3111-1  
CAN/CSA-C22.2 No 1010.1-92

### 6 – Electromagnetic Compatibility (EMC)

- CE conformity EMC standard 89/336/EEC
- Emission EN 50081-2, EN 61000-3-2/3
- Interference Immunity EN 50082-2

Specifications are subject to change without notice.



**IBEKO POWER AB**

Box 1346, 181 25 LIDINGÖ, SWEDEN, TEL: +46 8 731 76 99, FAX: +46 8 731 77 99, sales@dv-power.com, www.dv-power.com