



Micro Ohmmeter RMO100G

- Lightweight - only 8 kg
- Powerful 5 A – 100 A DC
- Measuring range 0 – 999,9 m Ω
- Resolution to 0,1 $\mu\Omega$
- SINGLE / CONTIN Mode
- True DC current



High DC current resistance meter

Description

RMO100G is a Micro Ohmmeter based on state of the art technology, using the most advanced switch mode technique available today. RMO100G generates true DC ripple free current with automatically regulated test ramps. During the test RMO100G ramps with increasing current before measuring and decreasing current after the measurement. This eliminates magnetic transients. After the test current has been set, the automatic test procedure is started by pressing the START-button.

The RMO100G instrument can store up to 500 measurements. All measurements are time and date stamped. Using DV-Win software a test can be performed from a PC, and the results can be obtained directly at a PC. Communication between RMO100G and PC is through USB (as standard) or RS232 cable (as an option). Using DV-Win the result can be arranged as an Excel spreadsheet which can be later shown as a diagram and printed for a report.

The set is equipped with thermal and overcurrent protection. The RMO100G has very high ability to cancel electrostatic and electromagnetic interference in HV electric fields. It is achieved by very efficient filtration. The filtration is made utilizing proprietary hardware and software.

Output Ratings

The full output is available from the RMO100G at 230 V or 115 V Mains Supply.

Supply Voltage	Output Current	Full Load Voltage
230 V AC	100 A DC smoothed	6,0 V DC
115 V AC	100 A DC smoothed	6,0 V DC

Output current is filtered and has a ripple of less than 1 %. The RMO100G current output is rated at 100 A for 5 minutes at 25 °C ambient temperature.

CONTIN Mode

RMO100G can generate DC current continuously using the CONTIN menu. In this menu the current can be chosen the same way like in the SINGLE menu, but the duration of the test can be preset. The test is started pressing the START-button. During the test, a new result is shown on the display and stored into the PC (DV-Win) each second. Using DV-Win the result can be arranged as an Excel spreadsheet which can be later shown as a diagram and printed for a report.

Application

Typical application is measuring resistance of:

- ✓ High, middle and low voltage circuit breakers
- ✓ High, middle and low voltage disconnecting switches
- ✓ High-current bus bar joints
- ✓ Cable splices
- ✓ Welding joints

Recommended accessories

- ✓ Current cables 2 x 5 m 16 mm² with battery clips
- ✓ Sense cables 2 x 5 m with alligator clips
- ✓ DV-Win PC software
- ✓ Mains power cable
- ✓ Ground (PE) cable
- ✓ Cable bag

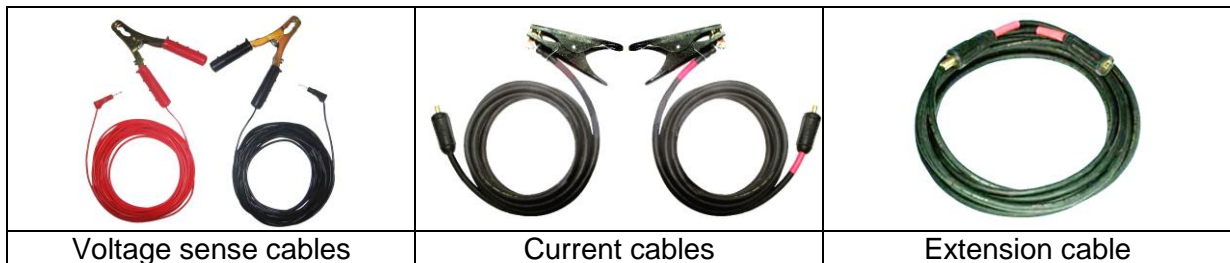

Optional accessories

- ✓ Built-in thermal printer
- ✓ Remote Control Unit
- ✓ Both Sides Grounded Unit
- ✓ Test shunt 600 A / 60 mV
- ✓ Current cables 2 x 10 m 16 mm²
- ✓ Current cables 2 x 15 m 25 mm²
- ✓ Extension cable 2 x 10 m 25 mm²
- ✓ Sense cables 2 x 10 m with alligator clips
- ✓ Sense cables 2 x 15 m with alligator clips
- ✓ Cable plastic case

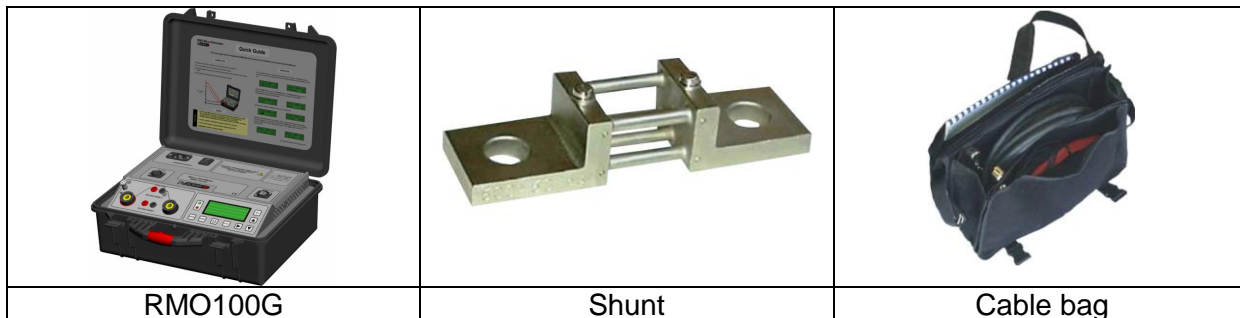

Connecting a Test Object to RMO100G

With RMO100G turned off, connect RMO100G to the test object (R_x) in such a way that the measuring cables from the "Voltage Sense" sockets are attached as close as possible to R_x , and in between the current feeding cables. That way, resistance of both cables and clamps is almost completely excluded from the resistance

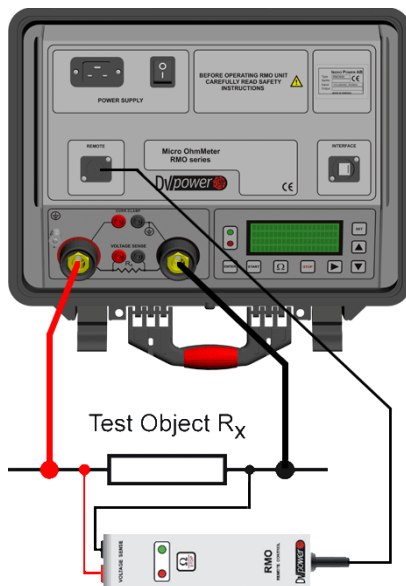
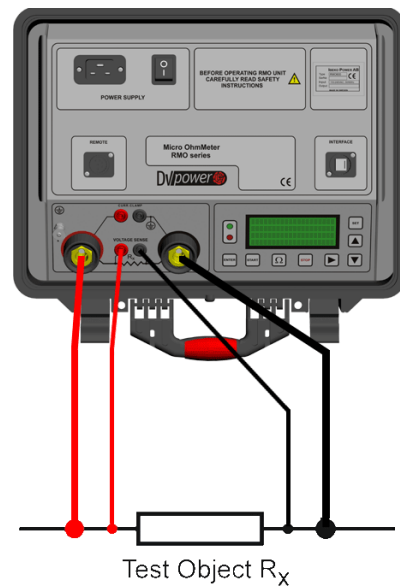

Remote Control Unit

The RMO Remote Control Unit is an optional control unit that is used to start and stop the tests from a remote location, away from the actual RMO.

Provided that, for a series of tests, the same test current is fed through the test object, multiple measurements can be carried out with the RMO Remote Control Unit.

Both Sides Grounded Unit

Using RMO100G with both sides grounded option it is possible to make safer measurement of breakers with both terminals of the breaker grounded. Measuring the current through the ground connection and reducing this value from the total current is an additional safety feature.

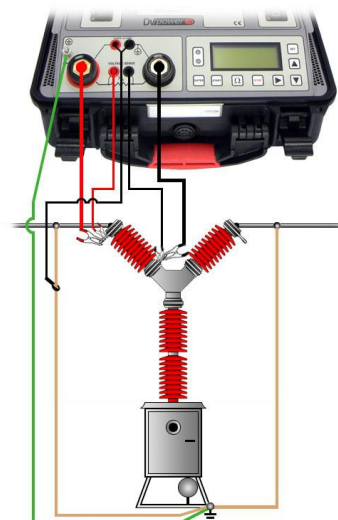

Technical data

1 - Mains Power Supply

- Voltage 110 – 230 V AC
- Frequency 50 – 60 Hz
- Input power 1160 VA
- Fuse 12 A / 230 V, type F

2 - Output data

- Test current 5 A – 100 A DC
- Measuring range / Resolution
 - 0,1 $\mu\Omega$ - 999,9 $\mu\Omega$ 0,1 $\mu\Omega$
 - 1000 $\mu\Omega$ - 9999 $\mu\Omega$ 1 $\mu\Omega$
 - 10,00 m Ω - 99,99 m Ω 10 $\mu\Omega$
 - 100,0 m Ω - 999,9 m Ω 0,1 m Ω
- Typical accuracy \pm (0,2 % rdg + 0,2 % FS)

3 - Environment conditions

- Altitude below 2000 m
- Temperature -10 °C - +55 °C / 14 °F - +131 °F
- Maximum relative humidity 95 % for temperatures up to 31 °C, decreasing linearly to 40 % relative humidity at 55 °C
- Mains supply voltage fluctuations up to \pm 10 % of the nominal voltage
- Installation/overvoltage category II
- Pollution degree 2

4 - Dimensions and Weight

- Dimensions 410 mm x 180 mm x 320 mm
16,14 in x 7,08 in x 12,59 in
(W x H x D) without handle
- Weight 9 kg / 20 lb

5 - Warranty

three years

6 - Safety Standards

- European standards EN 61010-1
LVD 2006/95/EC
- International standards IEC 61010-1
UL 61010-1
CAN/CSA-C22.2 No. 61010-1, 2nd edition, including
Amendment 1

7 - Electromagnetic Compatibility (EMC)

- CE conformity EMC standard 89/336/EEC
EMC directive 2004/108/EC
- Emission EN 61326-1
- Interference Immunity EN 61326-1

*Specifications are subject to change without notice.



IBEKO POWER AB